

CROSS-CONNECTION

AND

BACKFLOW PREVENTION MANUAL



Office of Environmental Health Services

West Virginia Department of Health and Human Resources
Environmental Engineering Division

CROSS-CONNECTIONS AND BACKFLOW PREVENTION MANUAL

Joe Manchin III
Governor

Martha Yeager Walker
Secretary
Department of Health and Human Resources

Chris H. Curtis, M. P. H
Acting Commissioner
Bureau for Public Health



**Department of Health and Human Resources
West Virginia Bureau for Public Health
Office of Environmental Health Services
Environmental Engineering Division
Capitol and Washington Streets
1 Davis Square, Suite 200
Charleston, WV 25301-1798**

Revised April, 2007

Introduction

The goal of a good public water supply system is to provide clean and safe drinking water to its customers. However, it is not enough to merely treat the water and meet regulatory standards. The water must also be protected in the distribution system so that it remains free of contamination. Cross-connections and backflow pose dangers to drinking water and public health once the water enters the distribution system. In order to address this problem, West Virginia's Cross-Connections and Backflow Prevention Regulations were adopted in April 1976 (revised and adopted again in March 2004). The Regulations require each public water supplier to develop and maintain a cross-connection control program in order to provide some control over water in the distribution system.

This manual is provided by the West Virginia Division of Health and Human Resources, West Virginia Bureau for Public Health, to be used as a reference document and training manual for public water supply personnel, health officials, plumbers and others involved in water supply distribution systems. As a supplement to the Regulations, this manual presents the basics of backflow theory, as well as, practical applications for cross-connection control.

TABLE OF CONTENTS

1. Backflow Theory	1
2. Backflow Incidents	4
3. Backflow Prevention Assemblies/Devices	
3.1 Air Gap	6
3.2 Reduced Pressure Principle Backflow Preventer	7
3.3 Double Check Valve Assembly	8
3.4 Double Check Valve with Intermediate Atmospheric Vent	9
3.5 Residential Dual Check	10
3.6 Vacuum Breakers	11
3.7 Barometric Loop	13
3.8 Interchangeable Connection	14
4. Selection of Assemblies/Devices	
4.1 Approval	15
4.2 Degree of Hazard	15
4.3 Containment	16
4.4 Isolation	17
4.5 Potential Contamination	18
4.6 Miscellaneous Applications	19
5. Installation of Assemblies/Devices	
5.1 Reduced Pressure Device	20
5.2 Double Check Valve Assembly	20
5.3 Atmospheric Vacuum Breaker	20
5.4 Pressure Vacuum Breaker	20
5.5 Barometric Loop	21
6. Field Test Procedures	22
6.1 Reduced Pressure Device	23
6.2 Double Check Valve Assembly	26
6.3 Pressure Vacuum Breaker	29
Appendices	
A. Cross-Connection Control Program	31
B. Model Ordinance	33
C. Types of Facilities Requiring Inspection	41
D. Partial List of Plumbing Hazards	42
E. Sample Letter: Notification of Inspection	43
F. Sample Letter: Request for Device Installation	44
G. Sample Survey Form	45
H. Sample Test Report	46
I. Thermal Expansion	47
J. OSHA Regulations	48
K. Glossary	49
Bibliography	51

1. CROSS-CONNECTION & BACKFLOW THEORY

Backflow is the entry or flow into a public or potable water supply of unwanted liquids, gases or substances from any source. Backflow may be a result of backsiphonage or backpressure.

A Cross-Connection is any physical connection or other arrangement whereby backflow of liquids, gases or other substances into any public or potable water supply may occur.

For backflow to exist, two elements must be present - a physical link (cross-connection) and a pressure differential. The physical link may be provided by direct plumbing connection or submerged inlet. The pressure differential may be caused by high pressure on the contaminated side (backpressure) or a negative pressure on the supply side (backsiphonage).

Cross-Connections

A connecting link between the potable water supply and the source of contamination must exist for backflow to occur. Two basic types of cross-connections may be created. These are direct connections and submerged inlets (or indirect connections).

A direct connection is created by connecting one pipe to another pipe or receptacle. The connection may or may not be valved. This type of connection is often installed where it is necessary to supply potable water to an auxiliary piping system.

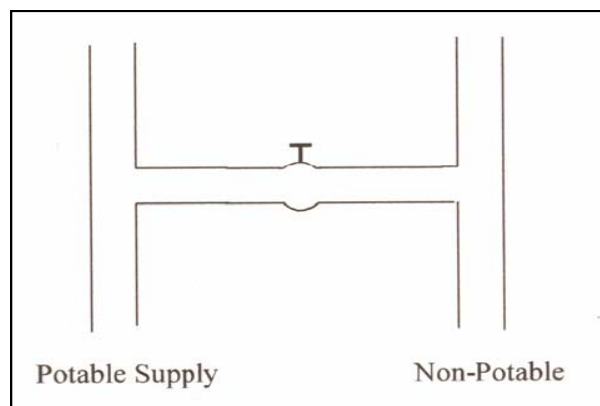

FIGURE 1 - Typical Direct Connection

A submerged inlet is a potable water supply inlet that is below the flood level rim of a receptacle. The flood level rim is the edge of the vessel or receptacle from which water overflows. A subset of this category is the garden hose which may be easily submerged in a liquid, connected to a garden sprayer or pushed down a drain.

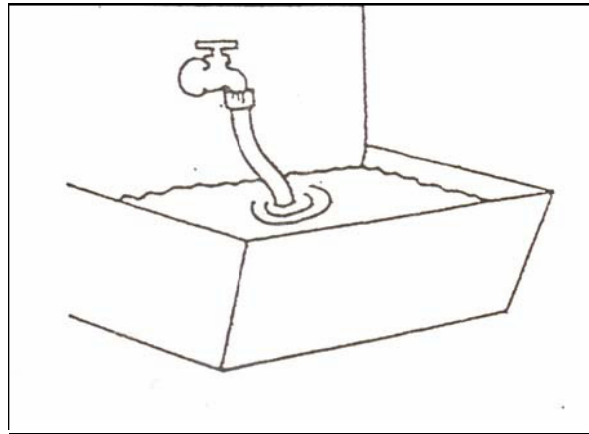

FIGURE 2 - Submerged Inlet

Backpressure

Backflow due to backpressure is caused by downstream pressure being higher than the supply pressure. Without proper protection, this pressure differential may result in reverse flow. Flow will always occur from the high pressure zone to the low pressure zone. Pumps, elevated tanks and boilers are likely to produce pressures higher than supply pressure and result in backflow.

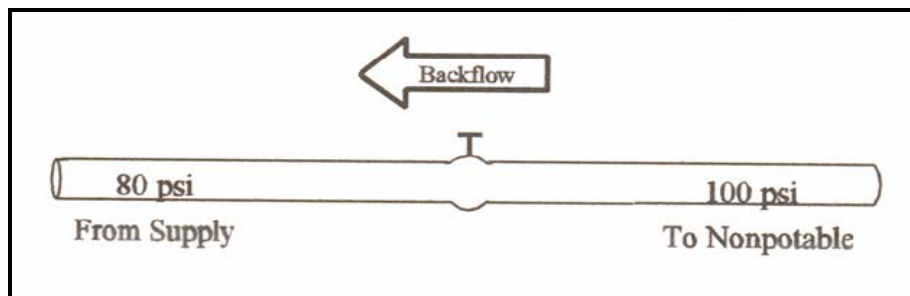

FIGURE 3 - Backflow due to Backpressure

Backsiphonage

Backsiphonage is backflow caused by a zone of negative pressure (pressure less than atmospheric) in a water system. If a cross-connection exists, atmospheric pressure pushing against a contaminant will force it into a potable water supply that contains a zone of negative pressure. The negative pressure is caused by a decrease in supply pressure due to such things as a water main break or fire hydrant use. The decrease in supply pressure causes a siphon effect resulting in a reversal of flow.

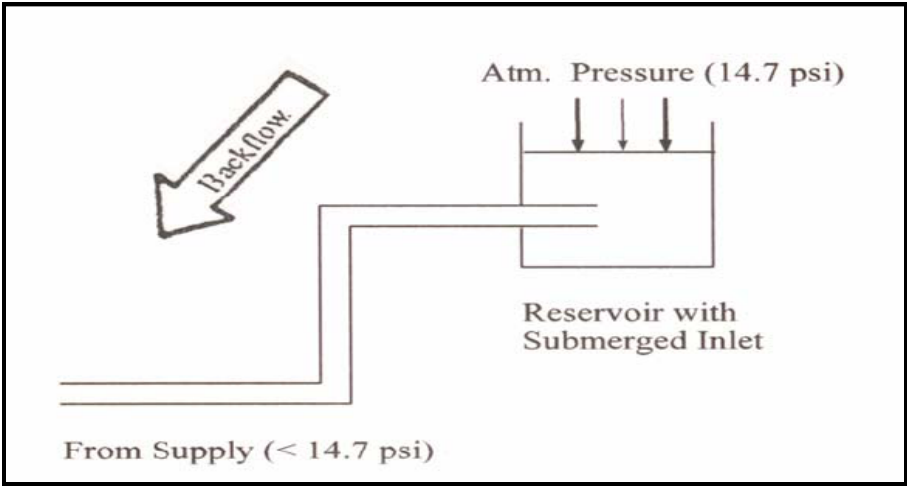

FIGURE 4 - Backsiphonage

2. BACKFLOW INCIDENTS

Several recent documented cases of water supply contamination due to backflow have occurred in the State of West Virginia.

In June 1994, discolored water at an elementary school was attributed to a corrosion control chemical that had been added to the Heating, Ventilating and Air-Conditioning system. Backflow of the chemical into the water supply occurred due to improper protection on boiler make-up water lines.

In September 1991, a small rural water supply discovered contamination in a main water distribution line resulting from backsiphonage of untreated pond water due to inadequate cross-connection protection at a golf course irrigation system.

In August 1991, a county health department discovered glycol contamination of their water supply. A faulty check valve allowed backflow of the chemical into the water supply resulting in the cancellation of all clinics until the situation was corrected.

In December 1981, water at an elementary school was found to be contaminated with anti-oxidants after a backflow preventer on the school's boiler feed line malfunctioned. The anti-oxidants were corrosive chemicals used to flush rust and other materials from the boiler system. Classes were canceled as a precaution.

In October 1981, a post office water system was discovered to have high nitrate levels and pink coloration attributed to backflow of a corrosion inhibitor from the post office chiller unit.

Several incidents of "blue water" have occurred across the state due to backsiphonage of toilet flush tank water. The presence of blue bowl cleaner in the water indicated a problem existed.

Serious cases of contamination have also occurred in other parts of the country.

In December 1980, 20,000 residents of the Pittsburgh area were without water for several weeks after contamination of their water supply by the pesticides chlordane and heptachlor. A cross-connection backsiphoned the pesticides from an exterminator truck into the water supply.

A similar incident occurred in Chattanooga in October 1979. Three gallons of chlordane was backsiphoned into the water supply of a residential area affecting approximately 50 homes. As a result the water utility was forced to replace water mains and lines, water heaters and the entire plumbing systems of several homes. Materials alone cost the water utility nearly \$1 million. Law suits resulted in millions of dollars worth of claims against the water company.

A cross-connection between a potable water system and a sewage system at a meat packing plant in Iowa in April 1979 caused sewage water to be sprayed on \$2,000,000 of pork in the plant.

The contamination cost the company to lose an estimated \$3,000,000 and resulted in extended unemployment time for 200 workers while the situation was cleaned up.

A well-documented case of backflow due to backpressure occurred at a Seattle car wash in February 1979. Complaints of “dirty”, “slippery” and “soapy” water in the area around the car wash led to the discovery of a cross-connection at the car wash. A temporary hose had been connected to a reclaimed water tank after a pump malfunctioned. The temporary connection was not removed after the pump was repaired causing reclaimed water/rinse water to be pumped into the city main. Approximately 100 square blocks of city water mains were contaminated.

Another documented case of backflow occurred in July 1978 aboard a U.S. Naval Ship. Gastrointestinal disease struck 544 crewmen aboard the ship. The illnesses resulted from a chilled drinking water system that was also supplying water to a tank used to mix photo-developing chemicals. A makeshift cross-connection (a rubber hose) leading to the tank allowed the developer to enter the potable water system.

Another publicized case ironically occurred at the Boston hotel hosting the 1974 National conference of the American Water Works Association. It was discovered that the hotel drinking water system had become contaminated during the conference with chromium through a submerged inlet cross connection in the building’s air conditioning system.

One of the most highly publicized cases of a backflow incident occurred in 1969 at Holy Cross University. The football season was canceled due to a large outbreak of infectious hepatitis among the team members. It was determined that backflow through an unprotected lawn sprinkler system at the practice football field caused the epidemic. Children carrying the hepatitis virus routinely played in puddles around the sprinkler heads. Fire fighting demands in the vicinity caused negative pressures at the sprinkler heads backsiphoning the contaminated water into the drinking water supply to the field.

One of the most famous cases of backflow occurred in California. A laborer had been using an aspirator attached to a garden hose to spray a driveway with weed-killer containing arsenic. At sometime during his work, the water pressure reversed. The man then disconnected the hose and unwittingly drank from the hose bibb. Arsenic in the waterline killed him.

These incidents and many others like them serve to illustrate the serious problems that can occur due to lack of cross-connection control and backflow prevention. Many other incidents likely occur, but go unnoticed or unreported, posing threats to health and safety.

3. BACKFLOW PREVENTERS

Backflow preventers are based on the principle of isolating contaminants or unapproved water from the potable water system. Buildings may be separated from the public water supply by installing backflow prevention assemblies at the meter (containment principle). Processes, equipment, laboratories, etc . . . within a facility may be isolated from the internal potable water supply using assemblies or devices (isolation principle).

Several types of backflow preventers are available and are approved for use in West Virginia. Each preventer is described in detail below. Criteria for selection of preventers are discussed in Section 4.

3.1 Air Gap

An air gap is a physical separation between the free flowing discharge end of a water supply pipe and an open to atmosphere receiving vessel. Air gaps are effective at preventing both backsiphonage and backflow due to backpressure. An air gap is measured vertically from the lowest end of the supply pipe to the flood level rim or highest possible water level of the fixture or tank into which it discharges. In general, the separation must be twice the supply pipe inside diameter, but never less than one inch. The close proximity of walls or obstructions will necessitate the use of a larger air gap. A larger air gap will also be required if foaming materials are added to the reservoir so that foam does not back up into the supply pipe.

Advantages:

- Very safe and reliable if properly installed and maintained
- Provide maximum protection due to physical separation of potable and nonpotable water
- Easy to inspect

Limitations:

- Easy to bypass or defeat with funnels or hoses
- Supply pressure is lost, requiring reservoir and additional pumping equipment
- Undesirable splashing may occur
- Incoming water may be exposed to airborne contaminants or lose residual chlorine

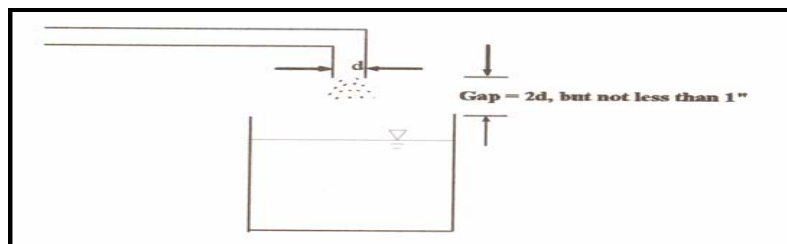

FIGURE 5 - Typical Air Gap

3.2 Reduced Pressure Principle Backflow Preventer

A Reduced Pressure Backflow Prevention assembly consists of two independently acting check valves, an automatically operated pressure differential relief valve located between the two check valves, and watertight valves located at each end of the assembly, together with four properly located test cocks for testing the operation of the backflow preventer.

These assemblies will indicate leakage through one or both check valves or the relief valve by the discharge of water from the relief valve port.

During normal operation, both check valves remain closed until there is a demand for water. The differential relief valve remains closed because the inlet pressure is higher than the pressure in the intermediate zone. The second check remains open as water flows through the assembly. In opening and closing the check valves, the water pressure may be reduced by 4 to 20 psi depending upon the assembly design.

During a backpressure condition, pressure increases downstream of the assembly and both check valves close to prevent backflow. If the second check valve is prevented from closing tightly, leakage back into the zone between the check valves will increase the pressure in the zone and cause the relief valve to open. Water in the zone will then be discharged.

During backsiphonage, the supply pressure drops and the relief valve opens automatically and drains enough water from the zone to maintain pressure in the zone lower than the supply pressure. The second check valve closes to prevent downstream water from draining through the relief valve.

Advantages:

- Protects against both backpressure and backsiphonage
- Can be used under constant pressure
- Excellent protection in health hazard installations
- Malfunctioning is easily indicated by discharge of water from the relief valve.

Limitations:

- Pressure loss of 4 to 20 psi across the device
- Installation above grade

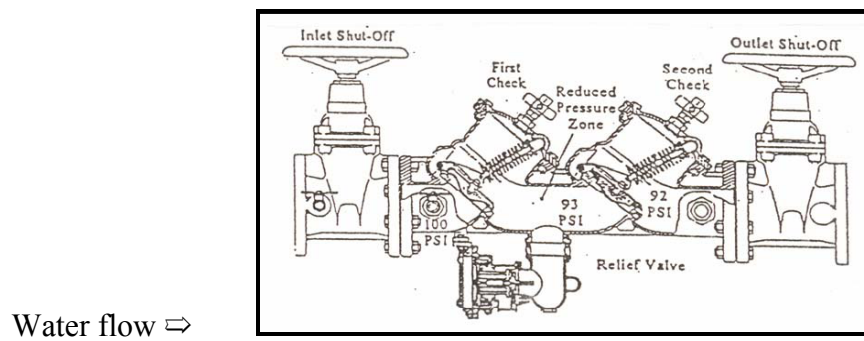

FIGURE 6 - Reduced Pressure Principle Backflow Preventer

3.3 Double Check Valve Assembly

A Double Check Valve assembly consists of two single independently acting check valves with watertight valves located at each end of the assembly, and four properly located test cocks for testing the water-tightness of each check valve. During normal operation, both check valves remain closed until there is a demand for water. In the event of backflow, both check valves close preventing reversal of flow. The double check valve assembly may be used to protect against either backsiphonage or backflow due to backpressure.

Two standard plumbing check valves in series may not be used in place of the double check valve assembly due to the necessity for testing. The Double Check Valve Assembly is an integral assembly designed specifically for backflow prevention.

Advantages:

- Protect against backflow due to both backpressure and backsiphonage
- May be used under continuous pressure
- Little pressure loss occurs across the assembly

Limitations:

- No external indication of failure
- May only be used in low hazard situations

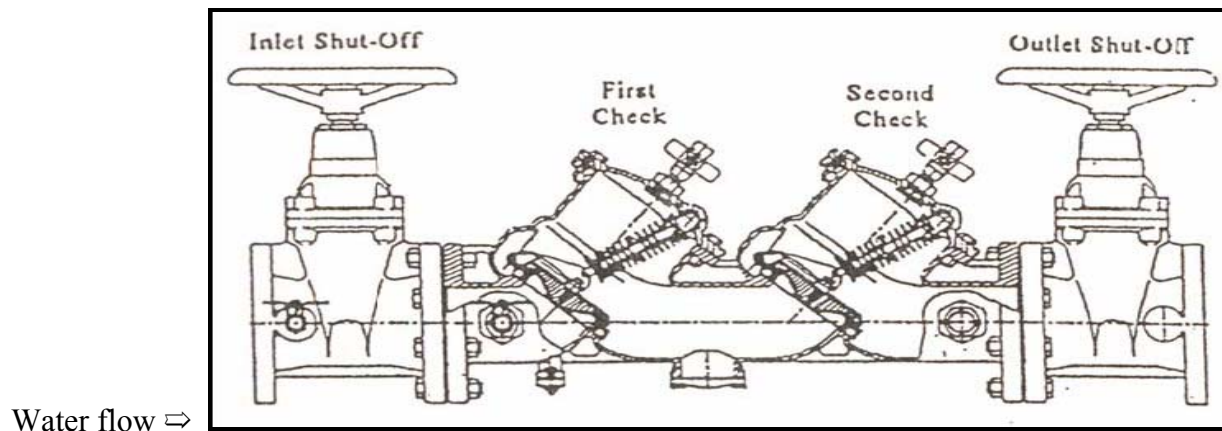

FIGURE 7 - Double Check Valve Assembly

3.4 Double Check Valve with Intermediate Atmospheric Vent

This device consists of two check valves with an atmospheric vent between the checks. During normal operation, both check valves remain closed until there is a demand for water and the vent is closed. When backsiphonage occurs, both checks close and the diaphragm is pushed away from the atmospheric vent opening allowing air to enter the air break chamber. When backpressure occurs, the checks are both closed and the vent is also closed. In the event that the secondary check should foul, the backpressure should force the vent open.

This device is used only in low hazard situations. This device is designed for use only on small ($\frac{1}{2}$ " - $\frac{3}{4}$ " diameter lines. These devices are typically used on residential service lines. For residential use, special consideration must be given to thermal expansion in the system.

Advantages:

- May be used to protect against backflow due to both backpressure and backsiphonage

Limitations:

- May only be used in non-health hazard situations
- Use requires approval of Environmental Engineering Division

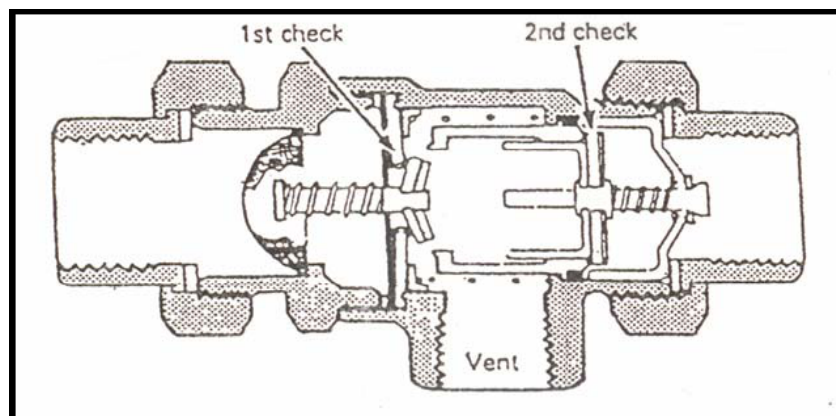

Water flow ⇒

FIGURE 8- Double Check Valve with Intermediate Atmospheric Vent

3.5 Residential Dual Check

Residential Dual Check Valve Backflow Preventers consist of two independently operating check valves. During normal operation, both check valves remain closed until there is a demand for water. In the event of backflow, both checks close to prevent reversal of flow. Dual Checks are designed for use only where a non-health hazard exists. They are sized for use on small supply lines (1" or less) and are to be installed immediately downstream of the meter. Dual Checks may be used for continuous pressure applications and will protect against both backsiphonage and backpressure.

NOTE: Consideration must be given to thermal expansion problems that may arise in the home after installation of a dual check device. Appendix I contains information on thermal expansion.

Advantages:

- Protect against both backsiphonage and backpressure
- May be used under continuous pressure
- Inexpensive

Limitations:

- May be used for non-health hazard situations only
- May be used only for residential applications
- No external indication of failure

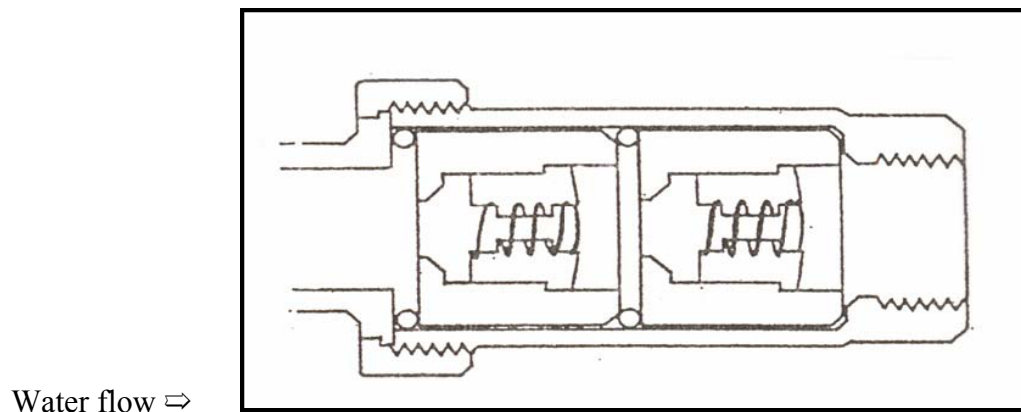

FIGURE 9 - Residential Dual Check

3.6 Vacuum Breaker

A Vacuum Breaker consists of a moveable disc or check valve and an atmospheric vent designed so that a pressure less than atmospheric in the supply line will open the vent, admit air at atmospheric pressure and prevent backsiphonage. Two types of vacuum breakers are generally available, the Atmospheric Vacuum Breaker and the Pressure Vacuum Breaker.

The atmospheric vacuum breaker uses gravity to actuate the atmospheric vent whenever water flow stops. The device usually consists of a float which is free to travel on a shaft and seal in the uppermost position against atmosphere with a disc. Water flow lifts the float, which then causes the disc to seal. Termination of the water supply will cause the disc to drop down venting the unit to atmosphere and opening the downstream piping to atmospheric pressure, thus preventing backsiphonage. The device is designed to be installed downstream of the last valve in the system and to be operated under pressure for no more than twelve hours in any twenty-four-hour period.

A special application of the atmospheric vacuum breaker is the hose bibb vacuum breaker. Hose bibb vacuum breakers are generally attached to sill cocks and in turn to hoses. The device consists of a spring loaded check valve that seals against an atmospheric outlet when water is flowing. When the water supply is turned off, the device vents to atmosphere, thus protecting against backsiphonage.

The pressure vacuum breaker uses spring loading to actuate the atmospheric vent only when backsiphonage occurs or when the line is depressurized. This assembly differs from the atmospheric vacuum breaker in that a spring has been added on top of the disc and float assembly. Two gate valves, test cocks and an additional first check are also added. This assembly is designed to be used under constant pressure conditions.

Advantages:

- Inexpensive

Limitations:

- Does not protect against backflow due to backpressure.
- May only be used in low hazard situations

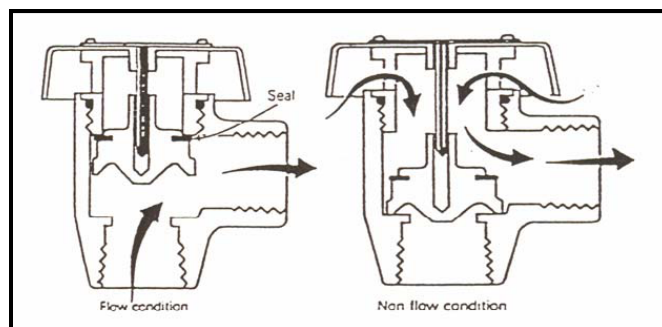

FIGURE 10 - Atmospheric Vacuum Breaker

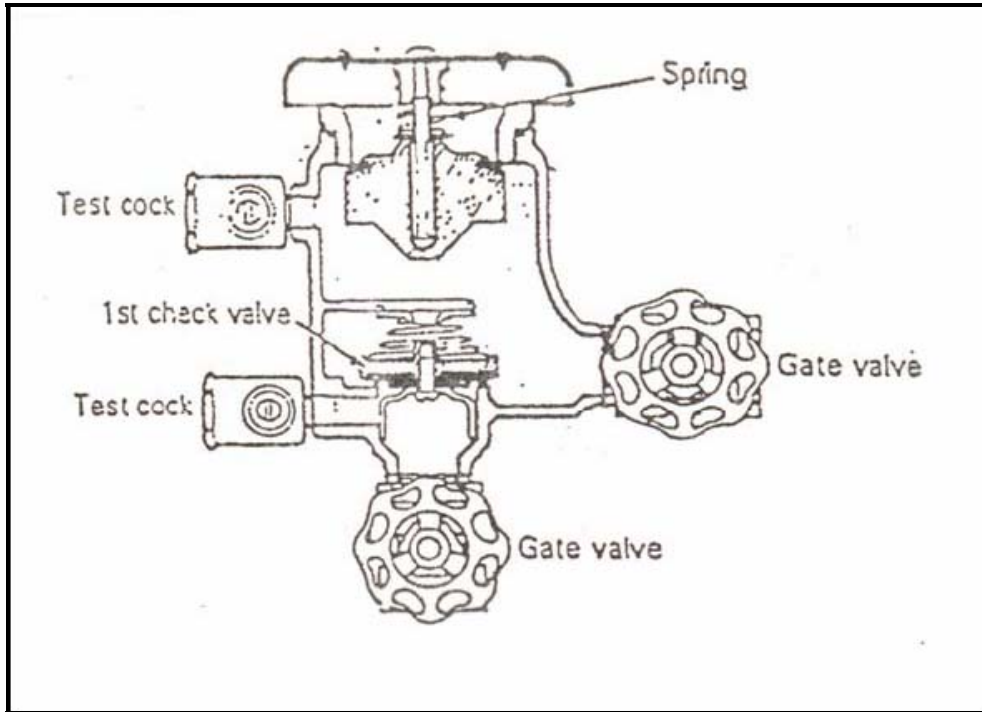

FIGURE 11 - Pressure Vacuum Breaker

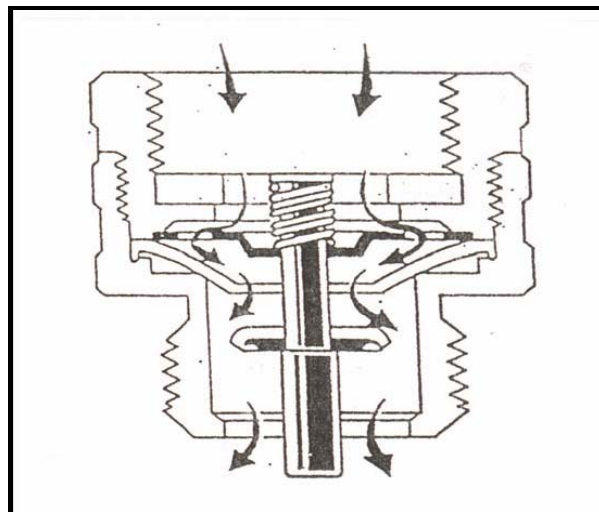

FIGURE 12 - Hose Bibb Vacuum Breaker

3.7 Barometric Loop

A Barometric Loop consists of a continuous section of supply piping that abruptly rises to a height of approximately 35 feet above the highest outlet served by the pipe and then returns back down to the originating level. Its operation is based on the principle that a column of water at sea level pressure will not rise above 33.9 feet. The Barometric Loop may be used to protect against backsiphonage. It may not be used where backpressure may occur.

Advantages:

- Does not require maintenance checks

Limitations:

- Requires a large amount of space for installation
- Subject to changes and modifications that may destroy effectiveness

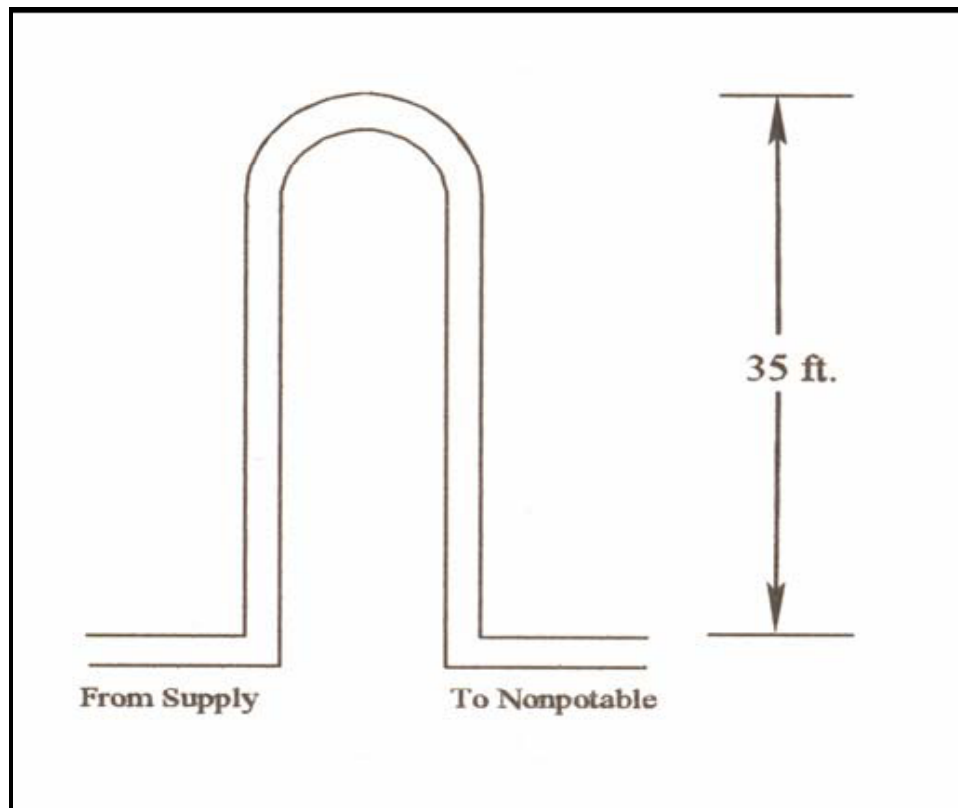

FIGURE 13 - Barometric Loop

3.8 Interchangeable Connection

An Interchangeable Connection is an arrangement or device that allows the alternate but not simultaneous use of two sources of water. The acceptable device is a four-way valve used in series with a Reduced Pressure Principle assembly. The Reduced Pressure Principle assembly is to be installed on the public water supply line upstream of the four-way valve.

A Four-way Valve in combination with a Reduced Pressure Principle assembly may be used where a plumbing system is supplied by both a public water supply and an unapproved auxiliary water supply. Four-way Valves provide air gap separation since one of the two sources is vented to the atmosphere. The separation prevents the secondary supply from continually being pumped against the public supply. The valve must be installed so that the line vented to the atmosphere will drain.

Advantages:

- simple, easy quarter-turn operation

Limitations:

- high pressure loss may occur through the four-way valve

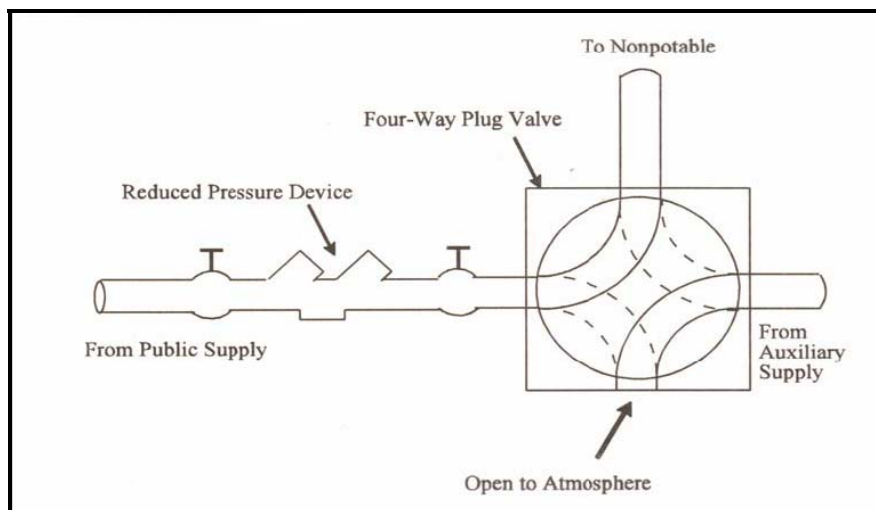

FIGURE 14 - Four-Way Plug Valve with Reduced Pressure Device

4. SELECTION OF ASSEMBLIES/DEVICES

Selection of the most appropriate approved backflow prevention assembly/device in any given situation depends on three factors: 1) the degree of hazard health present, 2) whether the assembly/device will be used for containment or isolation purposes, and 3) what potential contamination could affect the public water supply.

4.1 Approval

Any backflow preventer assembly used must be of a type that is approved by the West Virginia Bureau for Public Health, Environmental Engineering Division. All backflow preventers that have been certified as meeting the standards of the

- American Water Works Association (AWWA) and/or the
- American Society of Sanitary Engineers (ASSE) and/or the
- Foundation for Cross Connection Control Research - University of Southern California (FCCCR-USC)

are approved for use by the Environmental Engineering Division. The Environmental Engineering Division does not maintain a list of approved assemblies/devices.

4.2 Degree of Hazard

The degree of hazard is the potential risk to health and the potential adverse effects upon the public water supply based on the probability of backflow occurring and the type or nature of the contaminant. A health hazard is any condition, device or practice which creates or may create a danger to the health and well being of the water consumer. A severe health hazard is any health hazard that could be expected to result in significant morbidity or death. A non-health hazard is any condition, device or practice that could degrade water quality or adversely affect the public water supply system.

In cases where a severe health hazard exists, an approved Air Gap is to be used.

Where a health hazard exists, an approved Air Gap or Reduced Pressure Principle Backflow Preventer must be used.

An approved Air Gap, Reduced Pressure Principles or Double Check Valve Assembly shall be used where the public water supply may be contaminated by a non-health hazard where substances could degrade water quality or adversely affect the public water supply system.

An approved non-removable vacuum breaker device or barometric loop may be installed where the degree of hazard is low and where backflow can occur by backsiphonage only.

Table 1 - Acceptable Backflow Prevention Devices Based on Degree of Hazard				
	Severe Health Hazard	Health Hazard	Non-Health (Low) Hazard	
			Backsiphonage	Backpressure
Air Gap	X	X	X	X
Reduced Pressure Principle Assembly		X	X	X
Double Check Valve Assembly			X	X
Vacuum Breaker			X	
Barometric Loop			X	

4.3 Containment - Health and Non-Health Hazards

For containment purposes a backflow prevention assembly is to be installed on the service line to a premises where it has been determined that a potential or actual health hazard or other degradation of the public water supply exists. A backflow prevention assembly must be installed on the service line to the following facilities as referenced in Section 64-15-5,5.2 of the Cross Connection and Backflow Prevention Regulations.

1. Hospitals, mortuaries, clinics, nursing homes, animal hospitals
2. Laboratories
3. Sewage treatment plants, sewage pumping stations, storm water pumping stations
4. Chemical plants, dyeing plants, metal plating industries, tanneries
5. Petroleum processing or storage plants
6. Slaughterhouses, poultry processing plants, food or beverage processing plants
7. Piers, docks, waterfront facilities
8. Photo development plants
9. Car washes, laundromats
10. Public swimming pools
11. Farms where water is used for other than household purposes
12. Premises with internal cross connections that are not correctable or with intricate plumbing arrangements which make it impractical to determine if cross connections exist
13. Premises where, because of security requirements or other prohibitions or restrictions, it is impossible or impractical to make a cross-connection survey

14. Premises having a repeated history of cross connections being established or re-established

15. Other facilities specified by the Environmental Engineering Division.

Based on the degree of hazard expected to be present at the above facilities, these facilities require a minimum of a Reduced Pressure Principle assembly to be installed on the major service line to the facility.

If after review, no actual or potential health hazard is found to exist, a Double Check Valve Assembly may be used after approval by the Public Water System.

On service lines supplying fire sprinkler systems only, the service line must be protected by a minimum of two approved Check Valves. One of these check valves may be the Alarm Check provided as part of the sprinkler system. The other may be a Detector Check, Double Check Valve Assembly or an approved Single Check Valve that is UL approved.

Table 2 - Acceptable Backflow Prevention Devices for Containment			
	Health Hazard	No Health Hazard	Fire Sprinkler Systems
Air Gap	X	X	
Reduced Pressure Principle Assembly	X	X	
Double Check Valve Assembly		X*	
Two Check Valves			X**

* Requires pre-approval of Environmental Engineering Division

** See discussion above

4.4 Isolation - Health and Non-Health Hazards

An approved backflow prevention assembly or device must be used to isolate the following systems from potable and public water supply systems unless the Environmental Engineering Division determines that no health hazard exists:

1. Lawn sprinkler systems, irrigation systems
2. Fire service systems
3. Laboratory facilities

Other systems may also need to be isolated with backflow assemblies or prevention devices.

Review by the water purveyor or the Environmental Engineering Division will determine the necessity of backflow prevention assembly or device installation.

For internal protection of systems where both backsiphonage and backpressure may occur, a Reduced Pressure Principle assembly is required. In some low hazard cases a Double Check Valve with Intermediate Atmospheric Vent may be used after approval by the Community Public Water System.

For internal protection where non-health hazard exists and back pressure cannot occur, Vacuum Breakers may be used. Atmospheric Vacuum Breakers must be located on the discharge side of the last valve on the line serving the fixture or equipment and must be placed at least six inches above the highest outlet (12 inches for lawn sprinkler systems). Atmospheric Vacuum Breakers may not be used where supply pressure is continuous. Pressure Vacuum Breakers must be used if a valve is located on the discharge side of the device or where a vacuum breaker cannot be placed the required distance above the outlet. Pressure Vacuum Breakers may be used where supply pressure is continuous.

Boiler Feed Lines are required to have a Reduced Pressure Principle assembly installed.

Laboratories must be isolated from the remainder of the premises with a Reduced Pressure Assembly.

Lawn sprinkler or irrigation systems must be isolated and may be isolated using either an Atmospheric or Pressure Vacuum Breakers. If an Atmospheric Vacuum Breaker is used, it must be installed at least 6 inches above the highest sprinkler head. If a Pressure Vacuum Breaker is use, it must be installed at least 12 inches above the highest sprinkler head.

Table 3 - Acceptable Backflow Prevention Devices for Isolation					
	Backpressure	Backsiphonage	Boilers	Labs	Lawn Sprinklers
Air Gap	X	X	X	X	
Reduced Pressure Principle Assembly	X	X	X	X	
Double Check Valve with Atmospheric Vent	X*	X*			
Vacuum Breaker		X			X

* Requires pre-approval of Environmental Engineering Division

4.5 Potential Contamination

A potential contamination situation may exist due to a backflow incident in a water system. The potential contaminant(s) must be classified as either a “contaminant” or a “pollutant”. A

contaminant is defined as a foreign substance in the potable water system that could lead to a health hazard in the form of illness or death, for example, pathogens and chemical contaminants. A pollutant is defined as a foreign substance in the potable water system that could affect the color, odor, or taste, for example, dissolved minerals causing hardness and odor problems, or organic materials causing water discoloration. Generally, pollutants are non-health hazards.

4.6 Miscellaneous Applications

Auxiliary Water Supply: An approved air gap separation or an approved interchangeable connection with reduced pressure principle assembly must be installed at any point of connection between a public water supply and an auxiliary water supply that is not approved by the water purveyor. For approval of an auxiliary water supply, the owner must have a written statement from the water company acknowledging acceptance of the auxiliary water system, and the system must meet all public health laws, regulations and design standards. An approved auxiliary water supply may require installation at minimum a double check valve assembly or other approved backflow prevention assembly determined by the water purveyor.

Booster Pumps: any booster pump installed within a premises supplied by a public water supply or on the service line to such a premises must be equipped with a check valve on the discharge line and low pressure cut-off designed to shut-off the booster pump when the pressure in the service line on the suction side of the pump drops to twenty (20) psig or less, unless it is determined by the Environmental Engineering Division that an adequate supply exists to prevent the creation of negative pressure in the service line.

Pumping Stations: pumping stations within the public water supply distribution system must be equipped with a low pressure cut-off designed to shut off the pump when the pressure in the distribution line on the suction side of the pump drops to twenty (20) psig or less, unless it is determined by the Environmental Engineering Division that an adequate supply exists to prevent the creation of a negative pressure in the distribution system.

Parallel Installation: At premises where backflow preventer assemblies are required and the public interest requires continuous uninterrupted service, two approved backflow assemblies shall be installed in parallel and properly valved to permit continuous operation, or service to the premises must be from two separate service lines protected by approved backflow prevention devices.

5. INSTALLATION OF DEVICES

5.1 Reduced Pressure Principle Backflow Prevention Assembly

Reduced pressure devices must be

- installed so as to be readily accessible for inspection, testing and maintenance
- provided with adequate space for inspection, testing, maintenance and disassembly
- installed 12" - 30" above floor
- installed at least 12" from wall
- protected from freezing
- mounted in the horizontal position unless specifically designed for vertical installation
- installed above ground or floor level
- installed so that there is a visible free discharge from the relief port with no extension piping

NOTE: Installation in pits or in below grade vaults is prohibited.

5.2 Double Check Valve Assembly

Double check valve assemblies are to be installed so as to

- permit easy access
- provide adequate space for maintenance, inspection, testing and disassembly
- be 12" - 30" above floor
- prevent submergence
- be protected from freezing

5.3 Atmospheric Vacuum Breaker

Atmospheric vacuum breakers are to be

- installed at least six (6) inches above the flood level rim of fixtures or equipment served
- installed only where not subject to backpressure
- located downstream of all shut-off valves
- installed only where not subject to constant pressure
- protected from freezing
- accessible for inspection, testing, maintenance

5.4 Pressure Vacuum Breaker

Pressure vacuum breakers are to be

- installed at least twelve (12) inches above the flood level rim of fixtures or equipment served
- installed only where not subject to backpressure
- protected from freezing
- accessible for inspection, testing, maintenance

5.5 Barometric Loop

Barometric loops are to be

- protected from freezing
- installed only where not subject to backpressure
- at least 35 feet above the highest outlet

6. FIELD TEST PROCEDURES

Notification

For tests initiated by water company personnel, permission must be obtained from the owner of the assembly to shut down the water supply. Since all testing is accomplished under no-flow conditions, the water supply will be temporarily shut off while the testing is performed. The owner must also be cautioned that any inadvertent use of water within the building during the test will reduce the water pressure to zero possibly causing backsiphonage from any unprotected cross-connections. It may also be necessary to notify local fire departments before shutting down fire sprinkler systems.

Testers

As required in the “Certification of Backflow Prevention Assembly Testers Regulations”, all backflow prevention assembly testers must be certified by the WV Bureau for Public Health as qualified to inspect and test assemblies. In addition, testers must know and observe general safety procedures for personal safety, confined spaces, elevated platforms, electrical hazards, etc.

Equipment

Properly calibrated gauge equipment is essential to insure accurate test data. Gauges should be checked for accuracy at least once a year and re-calibrated as necessary. The tester should observe the condition of the test gauge equipment during all steps of the test. The equipment should be observed for leakage or damage. The gauge should zero out when not pressurized and needle valves and fittings must be drip tight. The gauge should be drained after testing to protect against freezing.

Maintenance and Repair

Manufacturers’ repair/maintenance manuals should be consulted before attempting to disassemble an assembly. Specialized tools may be required for some procedures and large spring loads may be present in some designs. Only manufacturers’ replacement parts should be used for repairs. Immediately following repair, maintenance or replacement, the backflow assembly must be retested.

Typical test procedures for the Reduced Pressure Principle assembly, Double Check Valve Assembly and Pressure Vacuum Breaker are listed below. Variations of these methods exist and may be used where appropriate.

A sample test report is included in Appendix H.

6.1 Reduced Pressure Principle

Equipment Required:

- Differential Pressure Gauge - minimum range 0-15 psid (0.1 or 0.2 psid graduations)
- Three 6 ft. lengths of minimum 1/4" diameter high pressure hose
- 1/4" needle valves
- Three 1/4" IPS x 45° SAE flare connectors - brass
- Adapter fittings 1/8" x 1/4", 1/4" x 1/2", 1/4" 3/4" - brass

Preliminary Steps:

- Look for signs of leakage from the relief port valve.
- Inspect for conditions which could prevent normal functioning of the assembly, plugged relief valve port, etc . . .
- Determine if the assembly has been properly installed above ground or floor level and is protected from freezing.
- Determine if any discharge from the relief valve port would be visible and that the port is not directly connected to a sewer.

Test No. 1 - Relief Valve Opening Point

Purpose: To test the operation of the differential pressure relief valve.

Requirement: The differential pressure relief valve must operate to maintain the zone between the two check valves at least 2 psi less than the pressure of the supply side of Check Valve No. 1.

Steps: A. Bleed the test cocks in the following order. First open test cock No. 4 and leave it open while bleeding each of the other test cocks individually starting with No.1, then No.2 and the No. 3. Open each of these three test cocks slowly and then close before proceeding to the next one. After test cocks 1 through 3 have been flushed and shut off, then close test cock No. 4.

- B. Install appropriate fittings to attach gauge hoses to test cocks No. 2, 3 and 4.
- C. Attach hose from high side of the differential pressure gauge to the No. 2 test cock.
- D. Attach hose from low side of the differential pressure gauge to the No. 3 test cock.
- E. Open test cock No. 3 slowly and then bleed all air from the hose and gauge by opening the low side bleed needle valve.

- F. Leaving the low side bleed needle valve open, slowly open test cock No. 2 and then bleed all air from the hose and gauge by opening the high side bleed valve.
- G. Close the high side bleed needle valve after all air is expelled, and then slowly close the low side needle valve.
- H. Close the No. 2 Shutoff Valve and note the position of the needle on the differential pressure gauge. If the needle continues to drop then the No. 1 Check Valve is leaking and the rest of the testing cannot be completed. If the needle remains steady, then note its position as the differential pressure drop across the No. 1 Check Valve.
- I. Open the high side control needle valve approximately one turn and then open the low side needle control valve no more than a quarter of a turn so that the differential gauge needle drops slowly. Observe the opening point of the relief valve by placing your hand where the water will drip on it and record the gauge reading when the relief valve first drips.
- J. Close the low side needle control valve.

Test No. 2 - Tightness of the No. 2 Check Valve

Purpose: To test the No. 2 Check Valve for tightness against backpressure.

Requirement: The No. 2 Check Valve shall be tight against backpressure.

Steps: A. Maintain the No. 2 Shut Off valve closed from the first test and the high side control needle valve open.

- B. Vent all of the air through the bypass hose by opening the bypass needle valve.
- C. With the bypass hose venting a small amount of water attach it to the No. 4 test cock and then close the bypass needle valve. After the bypass needle valve is closed, open the No. 4 test cock.
- D. Bleed water from the zone by opening the low side bleed valve on the gauge to re-establish the normal reduced pressure within the zone. Once the gauge needle reaches a value above the noted No. 1 Check Valve pressure drop (step H of Test No. 1), close the low side bleed valve.
- E. Open the bypass needle valve and observe the position of the needle on the gauge.

If the indicated differential pressure reading remains steady then the No. 2 Check Valve is reported as “Closed Tight”. Go to Test No. 3.

If the differential pressure reading falls to the relief valve opening point, bleed water through the low side bleed needle valve until the gauge reaches a value above the noted No. 1 Check Valve pressure drop. If the gauge needle settles above the relief valve opening point, record the No. 2 Check Valve as “Closed Tight” and proceed to test No. 3. If the differential pressure gauge reading falls to the relief valve opening point again, then the No. 2 Check Valve is reported as “leaking” and Test No. 3 below cannot be completed.

If the differential pressure reading drops, but stabilizes above the relief valve opening point, the No. 2 Check Valve can still be reported as “Closed Tight”.

If the gauge needle continues to rise then a check for backpressure must be conducted and the situation corrected before testing can be completed.

Test No. 3 - Tightness of No. 1 Check Valve

Purpose: To determine the tightness of Check Valve No. 1, and to record the static pressure drop across Check Valve No. 1

Requirement: The static pressure drop across Check Valve No. 1 should be at least 3.0 psi greater than the relief valve opening point (see test No. 1). This 3.0 buffer will prevent the relief valve from discharging during small fluctuations in line pressure. A buffer of less than 3.0 psi does not imply a leaking Check Valve No. 1, but rather is an indication of how well it is sealing.

Steps: A. With the bypass hose connected to test cock No. 4 as in step c of Test No. 2 (high side control needle valve and bypass needle valve remaining open), bleed water from the zone through the low side bleed needle valve on the gauge until the gauge reading exceeds the noted No. 1 Check Valve pressure drop. Close the low side bleed needle valve. After the gauge reading settles, the reading is the actual static pressure drop across Check Valve No. 1 and should be recorded as such.

B. Close all test cocks on assembly and slowly open Shutoff Valve No. 2 returning assembly to service. Open high side and low side bleed valves to drain gauge and remove all hoses. Open all needle valves on gauge and drain water from the gauge.

6.2 Double Check Valve Assembly

Equipment Required:

- Differential Pressure Gauge - minimum range 0-15 psid (0.1 or 0.2 psid graduations)
- One 6 ft. length - minimum 1/4" diameter high pressure hose
- 1/4" needle valves
- One 1/4" IPS x 45° SAE flare connector - brass
- Adapter fittings 1/8" x 1/4", 1/4" x 1/2", 1/4" x 3/4" - brass
- Street ell, pipe nipple or tube
- Bleed-off valve

Preliminary Steps:

- Determine if the assembly has been installed properly

Test No. 1 - Tightness of No. 1 Check Valve

Purpose: To determine the static pressure drop across Check Valve No. 1

Requirement: The static pressure drop across Check Valve No. 1 shall be at least 1.0 psi.

Steps: A. Flush all four test cocks of assembly one at a time to remove any foreign material.

- B. Install appropriate fittings to attach differential pressure gauge to test cock No. 2 and to attach a vertical sight tube to test cock No. 3 if it is not located at the highest part of the assembly body so that the top of the sight tube extends above the body of the assembly.
- C. Attach a vertical sight tube or pipe to test cock No. 3 if it is not located at the highest part of the body of Check Valve No. 1, so that the top of the tube or pipe extends above the highest part of the check valve body.
- D. Attach the high side differential pressure gauge hose to test cock No. 2
- E. Open test cock No. 2 and bleed all air from the hose and gauge by opening the high side bleed needle valve on the gauge, then close the high side bleed needle valve. If a tube or pipe is attached to test cock No. 3, open test cock No. 3 to fill the tube, and then close test cock No. 3.
- F. Close Shut Off Valve No. 2, then close Shut Off Valve No. 1
- G. Slowly open test cock No. 3 and observe the differential pressure gauge. When the gauge reading stabilizes and the water stops flowing out of test cock No. 3 the indicated pressure drop across the No. 1 Check Valve should be

recorded on the test form. When reading the differential pressure gauge, the centerline of the gauge must be held at the same elevation as test cock No. 3 or if a sight tube or pipe is used at the level of the water surface in the attached tube.

NOTE: If water continues to flow out of test cock No. 3 or the attached tube then the assembly is reported as failing and the No. 1 and/or No. 2 Shut Off Valve is leaking and must be repaired. If the water level in the No. 3 test cock or attached sight tube recedes, then the assembly is reported as failing and the No. 2 Shut Off Valve must be repaired.

- H. Close test cocks 2 and 3, remove high side hose from test cock No. 2 and the sight tube from test cock No. 3 (if used). Then open Shut Off Valve No. 1 a couple of turns.

Test No. 2 - Tightness of No. 2 Check Valve

Purpose: To determine the static pressure drop across Check Valve No. 2.

Requirement: The static pressure drop across Check Valve No. 2 shall be at least 1.0 psi.

- Steps:
- A. Install appropriate fittings to attach differential pressure gauge to test cock No. 3 and to attach a vertical sight tube to test cock No. 4 if it is not located at the highest part of the assembly body so that the top of the sight tube extends above the body of the assembly.
 - B. Attach a vertical sight tube or pipe to test cock No. 4 if it is not located at the highest part of the body of Check Valve No. 2, so that the top of the tube or pipe extends above the highest part of the check valve body.
 - C. Attach the high side differential pressure gauge hose to test cock No. 3.
 - D. Open test cock No. 3 and bleed all air from the hose and gauge by opening the high side bleed needle valve on the gauge, then close the high side bleed needle valve. If a tube or pipe is attached to test cock No. 4, open the test cock to fill the tube, then close test cock No. 4.
 - E. Close Shut Off Valve No. 1
 - F. Slowly open test cock No. 4 and observe the differential pressure gauge. When the gauge reading stabilizes and the water stops flowing out of test cock No. 4 the indicated pressure drop across the No. 2 Check Valve should be recorded on the test form. When reading the differential pressure gauge, the centerline of the gauge must be held at the same elevation as test cock No. 4

or if a sight tube or pipe is used at the level of the water surface in the attached tube.

NOTE: If water continues to flow out of test cock No. 4 or the attached tube then the assembly is reported as failing and the No. 1 and/or No. 2 Shut Off Valve is leaking and must be repaired. If the water level in the No. 4 test cock or attached sight tube recedes, then the assembly is reported as failing and the No. 2 Shut Off Valve must be repaired.

- G. Close all test cocks, remove all test equipment, open Shut Off Valve No. 1 and then slowly open Shut Off Valve No. 2 to restore water service.

6.3 Pressure Vacuum Breaker

Equipment Required:

- Differential Pressure Gauge - minimum range 0-15 psid (0.1 or 0.2 psid graduations)
- One 6 ft. length - minimum 1/4" diameter high pressure hose
- 1/4" needle valves
- Two 1/4" IPS x 45° SAE flare connectors - brass
- Adapter fittings 1/8" x 1/4" - brass
- Bleed-off valve

Preliminary Steps:

- Look for signs of water leakage from the vent ports.
- Check for conditions that would prevent normal functioning of the assembly, coverage of the vent ports, obstruction of the internal float, etc . . .
- Determine that the device is not subject to backpressure due to the presence of boilers, elevated tanks, pumps, etc . . . downstream.
- Inspect for proper elevation and location in the water system.

Test No. 1 - Air Inlet Valve Opening Point

Purpose: To determine the pressure in the body when the air inlet valve opens.

Requirement: The air inlet valve shall open when the pressure in the body is no less than 1.0 psi above atmospheric pressure, and the air inlet valve shall be fully open when water drains from the body.

Steps: A. Remove the air inlet valve canopy and flush water out of test cocks to eliminate any foreign material.

- B. Install appropriate fittings to test cock to attach gauge hoses.
- C. Attach the high side hose of the differential pressure gauge to test cock No. 2, and open test cock No. 2.
- D. Bleed air from the hose and gauge by opening the high side bleed needle valve. After air is dispelled, close high side needle valve, then slowly close Shut Off Valve No. 2 and then Shut Off Valve No. 1.
- E. Slowly open the high side bleed needle valve no more than one-quarter (1/4) turn, being careful not to drop the gauge needle too fast. Record the differential pressure reading on the gauge when the air inlet valve opens. The reading must be 1 psi or greater. After the air inlet valve has opened, fully open the

high side bleed needle valve to drain the water from the body and observe that the air inlet valve is fully opened. If the high side bleed needle valve must be opened more than one-quarter turn to lower the pressure in the valve body, then the No. 1 Shutoff Valve is leaking and must be repaired.

- F. Close test cock No. 2 and remove test hose. Then open Shutoff Valve No. 1.

Test No. 2 - Check Valve Closing Point

Purpose: To determine the static pressure drop across the check valve.

Requirement: The static pressure drop across the check valve shall be at least 1.0 psi.

Steps: A. Attach high side hose of the differential pressure gauge to test cock No. 1, and open test cock No. 1

- B. Bleed all air from the gauge by opening the high side bleed needle valve. After air is dispelled from gauge, close high side needle valve, and then close Shutoff Valve No. 1.
- C. Open test cock No. 2 and allow water in body of valve to drain out. When flow of water stops and the needle settles, record the differential pressure reading indicated on the gauge. This gauge reading must be 1.0 psi or greater. If water continues to flow out of test cock No. 2, then Shutoff Valve No. 1 is leaking and must be repaired.
- D. Close test cocks No. 1 and No. 2 and remove gauge hose from assembly. Open Shutoff Valve No. 1 and then slowly open Shutoff Valve No. 2.
- E. Replace air inlet valve canopy.

APPENDIX A

SETTING UP A CROSS-CONNECTION CONTROL PROGRAM

1 Establish Authority

The first step in setting up a cross-connection control program for a municipality is writing an ordinance that establishes legal authority for the program and governs the program's implementation. Public Service Districts and private water companies should have written rules or policies that detail the requirements of the program. The ordinance or policies should address these items:

- Responsibilities - who is responsible for inspection, installation, testing and maintenance of backflow assemblies, maintaining records, etc . . .
- Technical provisions - types of assemblies to be used, inspection methods and frequency, testing requirements and frequency, etc . . .
- Corrective action and penalty provisions for violations - length of time allowed for compliance, number of repeat notices to be given, provision for disconnection of service for continued non-compliance
- Record keeping - types of records to be maintained, where and for how long records will be stored.

2. Inspect Facilities

To begin implementing a cross-connection control program, facilities served by your public water system should be inspected by you for the presence cross-connections and backflow prevention assemblies and to determine the degree of hazard present. The owner of the facility should be notified in advance about the date and purpose of the survey. Inspections should begin with suspected "severe hazard" facilities such as industrial plants, hospitals, laboratories and mortuaries. The focus of the inspections may be for containment (protection of the public water supply only, usually at meter) or isolation (protection of both the public water supply and the facility's internal potable water supply).

3. Enforcement

Once a facility is inspected, the owner/operator should be notified in writing by the public water system of problems found and corrective actions required. Notify the owner to remove all existing cross connections and/or install backflow prevention assemblies. The type of backflow prevention assembly required should be specified along with any installation instructions. A schedule for mandatory testing of the assembly should also be provided. The public water system should review and approve plans for the installation of assemblies. Re-inspection of the facility to determine compliance may be required. In most cases, the ultimate method of enforcement will be threat of service disconnection.

4. Record-Keeping

The public water system should develop a system for keeping records of inspection results, locations and types of installed assemblies/devices, tests and maintenance on assemblies and enforcement actions. As stated in the regulations, records must be maintained for a minimum of two years.

5. Public Education

Education about the dangers of cross-connections can play a vital role in gaining the acceptance and cooperation of your customers. Water bill enclosures, flyers, information booths at local events, door-to-door visits, newspaper ads, television or radio announcements, etc . . . may be appropriate methods of making information available. Ideally, the education program should include informing private citizens of dangers including auxiliary water supplies cross-connected with the public water system, submerged hoses, garden sprayers and toilet mechanisms.

APPENDIX B

MODEL CROSS-CONNECTION CONTROL ORDINANCE

I. Purpose

A. To protect the public potable water supply served by _____ (*water system*) _____ from the possibility of contamination or pollution by isolating, within its customers internal distribution system, such contaminants or pollutants which could backflow or back-siphon into the public water system.

B. To promote the elimination or control of existing cross-connections, actual or potential, health hazards between its customers in-plant potable water system, and non-potable systems.

C. To provide for the maintenance of a continuing program of cross-connection control, this will effectively prevent the contamination or pollution of all potable water systems by cross-connection.

II. Authority

A. By the Federal Safe Drinking Water Act of 1974, and the Code of West Virginia Chapter 16, Article 1 and Public Health Laws, WV Bureau for Public Health Chapter 1, Article 5B, the water purveyor has the primary responsibility for preventing water from unapproved sources, or any other substances, from entering the public potable water system.

B. _____ (*water system*) _____, Rules and Regulations, adopted.

III. Responsibility

The Water Purveyor shall be responsible for the protection of the public potable water distribution system from contamination or pollution due to the backflow or back-siphonage of contaminants or pollutants through the water service connection. If, in the judgment of the Water Purveyor, an approved backflow assembly is required at the water service connection to any customer's premises, the Water Purveyor, or his delegated agent, shall give notice in writing to said customer to install an approved backflow prevention assembly at each service connection to his premises. The customer shall, within 90 days install such approved assembly, or assemblies, at his own expense, and failure or refusal, or inability on the part of the customer to install said assembly or assemblies within ninety (90) days, shall constitute a ground for discontinuing water service to the premises until such assembly or assemblies have been properly installed.

IV. Definitions

A. Approved

Accepted by the Water Purveyor as meeting an applicable specification stated or cited in this regulation, or as suitable for the proposed purpose.

B. Auxiliary Water Supply

Any water supply, on or available, to the premises other than the purveyor's approved public potable water supply.

C. Backflow

The unintentional reversal of flow of water or other liquids, mixtures or substances, under positive or reduced pressure in the distribution pipes of a potable water supply from any source other than its intended source.

D. Backflow Preventer

An assembly, device or means designed to prevent backflow. Most commonly categorized as air gap, reduced pressure principle, double check valve assembly, pressure vacuum breaker, atmospheric vacuum breaker, hose bibb vacuum breaker, residential dual check, double check with intermediate atmospheric vent, and barometric loop.

D1. Air Gap

A physical separation sufficient to prevent backflow between the free-flowing discharge end of a potable water system and any other system. Physically defined as a distance equal to twice the diameter of the supply side pipe diameter but never less than one (1) inch.

D2. Atmospheric Vacuum Breaker

A device which prevents back-siphonage by creating an atmospheric vent when there is either a negative pressure or sub-atmospheric pressure in a water system.

D3. Barometric Loop

A fabricated piping arrangement rising at least thirty-five (35) feet at its topmost point above the highest fixture it supplies. It is utilized in water supply systems to protect against back-siphonage.

D4. Double Check Valve Assembly

An assembly of two (2) independently operating spring loaded check valves with tightly closing

Shutoff valves on each side of the check valves, and properly located test cocks for the testing of each check valve.

D5. Double Check Valve with Intermediate Atmospheric Vent

A device having two (2) spring loaded check valves separated by an atmospheric vent chamber.

D6. Hose Bibb Vacuum Breaker

A device which is permanently attached to a hose bibb and which acts as an atmospheric vacuum breaker.

D7. Pressure Vacuum Breaker Assembly

An assembly containing one or two independently operated spring loaded check valves and an independently operated spring loaded air inlet valve located on the discharge side of the check or checks. The assembly includes tightly closing shut-off valves on each side of the check valves and properly located test cocks for the testing of the check valve(s).

D8. Reduced Pressure Principle Backflow Preventer

An assembly consisting of two (2) independently operating approved check valves with an automatically operating differential relief valve located between the two (2) check valves, tightly closing shut-off valves on each side of the check valves plus properly located test cocks for the testing of the check valves and the relief valve.

D9. Residential Dual Check

A device consisting of two (2) spring-loaded, independently operating check valves. Generally employed immediately downstream of the water meter to act as an isolation device.

E. Backpressure

A condition in which the owner's system pressure is greater than the suppliers' system pressure.

F. Back-Siphonage

The flow of water or other liquids, mixtures or substances into the distribution pipes of a potable water supply system from any source other than its intended source caused by the sudden reduction of pressure in the potable water supply system.

G. Containment

A method of backflow prevention which requires a backflow prevention assembly at the water service entrance.

H. Contaminant

A substance that will impair the quality of the water to a degree that it creates a serious health hazard to the public leading to poisoning or the spread of disease.

I. Cross-connection

Any physical or other arrangement through which a backflow of liquids, or gases, or other substances into the Public Water System may occur.

J. Fixture Isolation

A method of backflow prevention in which a backflow preventer is located to correct a cross connection at an in-plant location rather than at a water service entrance.

K. Owner

Any person who has legal title to, or license to operate or reside in, a property upon which a cross-connection inspection is to be made or upon which a cross-connection is present.

L. Person

Any individual, partnership, company, public or private corporation, political subdivision or agency of the State Department, agency or instrumentality or the United States or any other legal entity.

M. Pollutant

A foreign substance, which if permitted to get into the public water system, will degrade its quality so as to constitute a moderate hazard, or impair the usefulness or quality of the water to a degree which does not create an actual hazard to the public health, but which does adversely and unreasonably affect such water for domestic use.

N. Water Purveyor

The Municipal Water Department, Water Board, Public Service District or other administrative authority invested with the authority and responsibility for the implementation of a cross-connection control program and for the enforcement of the provisions of the Ordinance.

O. Water Service Entrance

That point in the owner's water system beyond the sanitary control of the Water Purveyor: generally considered to be the outlet end of the water meter and always before any unprotected branch.

P. West Virginia Bureau for Public Health (WVBPH)

The State of West Virginia Bureau for Public Health

V. Administration

A. The Water Purveyor will operate a cross-connection control program, to include the keeping of necessary records, which fulfills the requirements of the WVBPH Cross-Connections and Backflow Prevention Regulations.

B. The Owner shall allow his property to be inspected for possible cross-connections and shall follow the provisions of the Water Purveyor's program and the WVBPH Regulations if a cross-connection is permitted.

C. If the Water Purveyor requires that the public supply be protected by containment, the Owner shall be responsible for water quality beyond the outlet end of the containment assembly and should utilize fixture outlet protection for that purpose. He may utilize local public health officials, or personnel from the Water Purveyor, or their designated representatives, to assist him in the survey of his facilities and to assist him in the selection of proper fixture outlet devices, and the proper installation of these devices.

VI. Requirements

A. Water Purveyor

1. On new installations, the Water Purveyor will provide on-site evaluation and/or inspection of plans in order to determine the type of backflow preventer, if any, that will be required.

2. For premises existing prior to the start of this program, the Water Purveyor will perform evaluations and inspections of plans and/or premises and inform the owner by letter of any corrective action deemed necessary, the method of achieving the correction, and the time allowed for the correction to be made. Ordinarily, ninety (90) days will be allowed. However, this time period may be shortened depending upon the degree of hazard involved and the history of the backflow preventer(s) in questions.

3. The Water Purveyor will not allow any cross-connection to remain unless it is protected by an approved backflow preventer which will be regularly tested to insure satisfactory operation.

4. The Water Purveyor shall inform the Owner by letter, of any failure to comply, by the time of

the first re-inspection. The Water Purveyor will allow an additional fifteen (15) days for the correction. In the event the Owner fails to comply with the necessary correction by the time of the second re-inspection, the Water Purveyor will inform the Owner by letter, that the water service to the Owner's premises will be terminated within a period not to exceed five (5) days. In the event that the Owner informs the Water Purveyor of extenuating circumstances as to why the correction has not been made, a time extension may be granted by the Water Purveyor, but in no case will exceed an additional thirty (30) days.

5. If the Water Purveyor determines at any time that a serious threat to the public health exists, the water service will be terminated immediately.

6. The Purveyor will begin initial premise inspections to determine the nature of existing or potential health hazards. Initial focus will be on severe health hazard industries and commercial premises.

B. Owner

1. The Owner shall be responsible for the elimination or protection of all cross-connections on his premises.

2. The Owner, after having been informed by a letter from the Water Purveyor, shall at his expense, install, maintain, and test, or have tested, any and all backflow preventer assemblies on his premises.

3. The Owner shall correct any malfunction of the backflow preventer assemblies which is revealed by periodic testing.

4. The Owner shall inform the Water Purveyor of any proposed or modified cross-connections and also any existing cross-connections of which the Owner is aware, but have not been found by the Water Purveyor.

5. The Owner shall not install a by-pass around any backflow preventer unless there is a backflow preventer of the same type on the bypass. Owners who cannot shut down operation for testing of the assembly(s) must supply additional assemblies necessary to allow testing to take place.

6. The Owner shall install backflow preventers in a manner approved by the Water Purveyor.

7. The Owner shall install only backflow preventers approved by the Water Purveyor or the WVBPH.

8. Any Owner having a private well or other private water source must have the approval of the Water Purveyor if the well or source is cross-connected to the Water Purveyor's system. Permission to cross-connect may be denied. The Owner may be required to install a backflow

preventer at the service entrance if a private water source is maintained, even if it is not cross-connected to the Water Purveyor's system.

9. In the event the Owner installs plumbing to provide potable water for domestic purposes which is on the Water Purveyor's side of the backflow preventer, such plumbing must have its own backflow preventer installed.

10. The Owner shall be responsible for the payment of all fees for permits, annual or semi-annual assembly testing, retesting in the case that the assembly fails to operate correctly, and second re-inspections for non-compliance with Water Purveyor or WVBPH requirements.

VII. Degree of Hazard

The Water Purveyor recognizes the threat to the public water system arising from cross-connections. All threats will be classified by degree of hazard and will require the installation of approved backflow prevention assemblies.

VIII. Existing In-Use Backflow Prevention Devices

Any existing backflow preventer shall be allowed by the Water Purveyor to continue in service unless the degree of hazard is such as to supersede the effectiveness of the present backflow preventer, or result in an unreasonable risk to the public health. Where the degree of hazard has increased, as in the case of a residential installation converting to a business establishment, any existing backflow preventer must be upgraded to a reduced pressure principle assembly, or a reduced pressure principle assembly must be installed in the event that no backflow assembly is present.

IX. Periodic Testing

A. Backflow prevention assemblies shall be tested and inspected at least annually.

B. Periodic testing shall be performed by a WVBPH certified tester. This testing will be done at the owner's expense.

C. Any backflow preventer assembly which fails during a periodic test will be repaired or replaced. When repairs are necessary, upon completion of the repair the backflow preventer assembly will be retested at owner's expense to insure correct operation. High hazard situations will not be allowed to continue unprotected if the backflow preventer assembly fails the test and cannot be repaired immediately. In other situations, a compliance date of not more than thirty (30) days after the test date will be established. The owner is responsible for spare parts, repair tools, or a replacement device. Parallel installation of two (2) devices is an effective means of the owner insuring that uninterrupted water service during testing or repair of devices and is strongly recommended when the owner desires such continuity.

D. Backflow prevention assemblies will be tested more frequently than specified in A. above, in cases where there is a history of test failures and the Water Purveyor feels that due to the degree of hazard involved, additional testing is warranted. Cost of the additional tests will be born by the owner.

X. Records

The Water Purveyor will initiate and maintain the following:

1. Master files on customer cross-connections
2. Master files on customer cross-connection tests and/or inspections
3. Copies of lists and summaries supplied to the WVBPH

Upon request, the Water Purveyor will submit records of inspection, surveys, tests or corrective actions to the West Virginia Bureau for Public Health.

APPENDIX C

TYPES OF FACILITIES REQUIRING INSPECTION

The following is a partial list of facilities that may require inspection for the existence of cross-connections and appropriate backflow prevention assemblies or devices. These types of facilities have historically posed a threat to the public water supply due to the presence of cross-connections.

Industries

Automotive manufacturing plants
Chemical, plating, processing plants, chemical tank car cleaning facilities
Breweries, bottling plants
Canneries, packing houses, meat processing operations
Dairy processing operations
Photographic developing laboratories
Research laboratories
Oil and gas production, storage or transmission operations
Power plants

Commercial Establishments

Hospitals, medical buildings, sanitariums, nursing or convalescent homes, clinics, dentist offices
Mortuaries, morgues, funeral homes
Refrigeration or cold storage plants
Laundries, dry cleaning operations
Car washes
Grain elevators
Restaurants, taverns
Beauty salons, barber shops
Greenhouses
Marinas

Other

Schools, churches
Parks
Golf courses (lawn sprinkling systems)
Cemeteries (lawn sprinkling systems)
Sewage treatment plants, sewage lift stations
Water treatment plants
Private homes with wells, swimming pools, lawn sprinkling systems
Apartment complexes

APPENDIX D

PARTIAL LIST OF PLUMBING HAZARDS

The following is a partial list of hazards that should be looked for and that may be encountered during inspections and surveys of facilities. The presence of any of these and other fixtures should be used to determine the degree of hazard present at a facility and the type of backflow preventer assembly or device required.

Fixtures with Direct Connections

Air Conditioning, air washer
Air Conditioning, chilled water
Air Conditioning, condenser water
Air line
Aspirator, laboratory
Aspirator, medical
Aspirator, herbicide and fertilizer sprayer
Autoclave and sterilizer
Auxiliary system, industrial
Auxiliary system, surface water
Auxiliary system, unapproved well supply
Boiler system
Chemical feeder, pot-type
Chlorinator
Coffee urn

Cooling system
Dishwasher
Fire standpipe or sprinkler system
Fountain, ornamental
Hydraulic equipment
Laboratory equipment
Lubrication, pump bearings
Photostat equipment
Plumber's friend, pneumatic
Pump, pneumatic ejector
Pump, prime line
Pump, water operated ejector
Sewer, sanitary
Sewer, storm
Swimming pool

Fixture with Submerged Inlets

Baptismal fount
Bathtub
Bedpan washer, flushing rim
Bidet
Brine tank
Cooling tower
Cuspidor
Drinking fountain
Floor drain, flushing rim
Garbage can washer
Ice maker
Laboratory sink, serrated nozzle

Laundry machine
Lavatory
Lawn sprinkler system
Photo laboratory sink
Sewer flushing manhole
Slop sink, flushing rim
Slop sink, threaded supply
Steam table
Urinal, siphon jet blowout
Vegetable peeler
Water closet, flush tank, ball cock
Water closet, flush valve, siphon jet

APPENDIX E

SAMPLE LETTER: NOTIFICATION OF INSPECTION

(Letterhead)

Date

Customer Name

Address

City, State, Zip

Dear Customer:

In accordance with the State of West Virginia Cross Connections and Backflow Prevention Regulations enacted April 1, 1976, (revised and accepted March 2004) the *(water company name)* has initiated a cross-connection and backflow prevention program. As part of this program, we will inspect your facility/home for the presence of cross-connections and determine the degree of hazard present. After inspection, you will be notified in writing of the results of the survey and any corrective action that will be necessary. You may be required to remove existing cross-connections or install backflow prevention assemblies or devices. Backflow is a reversal of normal flow in a drinking water distribution system. Normally, water flows from the water company's public water distribution (piping) system into your home or business. During backflow, water flows from your plumbing system back into the distribution system. Any contaminants that are picked up while the water is in your plumbing system could contaminate the water in the public water supply. Backflow may occur due to either a build-up of pressure that overcomes the pressure of the public water supply or to a loss of pressure in the distribution system that causes water to be siphoned from your plumbing system.

For backflow to occur, a cross-connection must exist. Two types of cross-connections exist, the direct connection and the submerged inlet. A direct connection is created by connecting one pipe to another pipe or container. A submerged inlet is a connection where incoming water enters a container below water level. The presence of either of these cross-connections may require that a backflow prevention assembly or device be installed on your premises.

You will be contacted to arrange a convenient time for the inspection. If you have any questions regarding the inspection please contact the *(water company name)* at *(telephone number)*. We appreciate your cooperation in helping us maintain a clean and safe water supply.

Sincerely,

(Name)

(Title)

APPENDIX F

SAMPLE LETTER: REQUEST FOR DEVICE INSTALLATION

(Letterhead)

Date

Customer Name

Address

City, State Zip

Dear Customer:

On *(date)* a survey was made of your facility/home for the purpose of locating cross-connections and determining the degree of hazard present. As a result of this survey, the following cross-connections were found:

(List cross-connections found and locations)

In order to safeguard the public water supply, the *(name of public water system)* based on West Virginia Bureau for Public health recommendations require that the following backflow prevention assemblies or devices be installed or actions be taken:

(List devices and locations, or disconnections required)

Installation of the above listed assemblies or devices must be completed within ninety (90) days. Failure to comply with the requirements will result in disconnection of water service to your premises. Installation instructions may be obtained from *(name of public water system)*. If you are required to install a Reduced Pressure Backflow Prevention Assembly, a Double Check Valve Assembly or a Vacuum Breaker, be advised that the assemblies require testing once per year to ensure that they are operating properly. An instruction for testing of assemblies is also available from *(name of public water system)*.

If you have any questions regarding these requirements, please contact the *(name of public water system)* at *(telephone number)*. We appreciate your cooperation in helping us maintain a clean and safe water supply.

Sincerely,

(Name)

(Title)

APPENDIX G

SAMPLE SURVEY FORM

CROSS-CONNECTION SURVEY

Customer: _____ Telephone: _____

Address: _____

Name of Contact: _____

Type of Use: Industrial ____ Commercial ____ Governmental ____ Other ____

Types of water use on premises: _____

Auxiliary Water Source Present? _____

Non-interrupted water service required? _____

Cross-Connections Found		
Type and Location	Type of Assembly/Device Required	Assembly/Device Present

Degree of Hazard: Severe ____ High ____ Low ____

Remarks: _____

Inspected By: _____ Survey Date: _____

Follow-Up Inspection: _____

APPENDIX H
SAMPLE TEST REPORT

BACKFLOW ASSEMBLY TEST AND MAINTENANCE REPORT

Customer: _____ Meter Number: _____
 Address: _____
 Location of Device: _____ New Installation? _____
 Type of Assembly: _____ Manufacturer: _____
 Model No.: _____ Size: _____ Serial No.: _____
 Height off Floor: _____ Protected from Freezing? _____ Flooding? _____

	Reduced Pressure Principle Assembly				
	Double Check Valve Assembly			Vacuum Breaker	
	Check Valve #1	Check Valve #2	Relief Valve	Air Inlet	Check Valve
Initial Test	Held at _____ psid Closed tight Leaked	Held at _____ psid Closed tight Leaked	Opened at _____ psid Did not open	Opened at _____ psid Did not open	Held at _____ Leaked
Repairs					
Final Test	Held at _____ psid Closed tight	Held at _____ psid Closed tight	Opened at _____ psid	Opened at _____ psid	Held at _____

Initial test by: _____ Date: _____
 Certification No.: _____

Repaired by: _____ Date: _____
 Certification No.: _____

Final test by: _____ Date: _____
 Certification No.: _____

APPENDIX I

THERMAL EXPANSION

The addition of backflow prevention devices to residential or residential-type water systems may result in a “closed-loop” system creating abnormally high and potentially dangerous internal pressures. Installation of pressure relief valves or bladder type accumulators may be necessary to eliminate the hazard.

Thermal expansion takes place in water heaters when water is heated. As the water is heated, it expands and increases in volume. Traditionally, the increased volume of water flows back into the supply line and into the public water supply main. With the addition of backflow preventers, check valves and pressure reducing valves on the supply line, a closed loop is formed and the water cannot flow back into the supply line. The volume of water then increases and the resultant pressure increases beyond what the hot water system is designed to handle. The increase in pressure causes the emergency relief valve on the water tank to open and discharge water creating a nuisance and resulting in inefficient operation. Excessive pressure may also rupture pipe fittings and lead to water heater explosion.

To eliminate this potential hazard, the owner must install pressure relief valves or accumulators in the plumbing system to relieve pressure.

APPENDIX J

OSHA REGULATIONS

Potable Water and Backflow Prevention

Occupational Safety and Health Administration regulations pertaining to backflow prevention are contained in the Code of Federal Regulations at 29 CFR Part 1910, Subpart J, Section 1910.141.

Section 1910.141 (5-b-1-I) states “Potable water shall be provided in all places of employment, for drinking, washing of the person, cooking, washing of foods, washing of cooking or eating utensils, washing of food preparation or processing premises, and personal service rooms.”

Section 1910.141 (5-b-2-ii) states “Construction of non-potable water systems or systems carrying any other non-potable substance shall be such as to prevent backflow or backsiphonage into a potable water system.”

Confined Spaces

Installation, maintenance or testing of backflow preventers located in confined spaces is subject to OSHA Confined Spaces regulations containing in 29 CFR Part 1910, Section 1910.146.

APPENDIX K

GLOSSARY

air gap. An open vertical drop, or physical separation between the free flowing discharge end of a water supply pipe and an open to atmosphere receiving vessel having a minimum unobstructed vertical distance between the supply discharge and flood rim level of receptacle twice the diameter of the supply line or one inch, whichever is greater.

assembly. An approved backflow preventer equipped with shut off valves and four test cocks. This arrangement allows for testing of the assembly.

backflow. A reverse in direction of flow created by a difference in water pressures causing water to flow back into the distribution pipes of a potable water supply. Also see, *backsiphonage* and *backpressure*.

backpressure. A pressure differential in a water system that causes water to flow back into the water supply when the water user's system is at a higher pressure than the public water system.

backsiphonage. A form of *backflow* created by a negative or below atmospheric pressure within a water system.

barometric loop. A backflow prevention device created by using a continuous section of a vertical supply pipe that rises to a height of approximately 35 feet above the highest outlet served then returns back down to its original level.

booster pumps. Pumps designed to maintain or to accelerate the water pressure in a distribution system.

contaminant. Any physical, chemical, biological, or radiological substance or matter that has an adverse effect on air, soil, or water. As related to drinking water, a substance(s) that creates a *health hazard* resulting in morbidity or mortality.

contamination. The introduction into water any liquid, solid, or gas that makes it undesirable or unfit for its next intended use.

cross-connection. Any physical connection or other arrangement between a drinking water system and an unapproved water supply or other source of contamination that may cause a liquid, gas or other substance to enter the public or potable water supply .

device. A single component mechanical unit designed for backflow prevention that cannot be tested and gives no indication of its condition.

double check valve assembly (DCVA). An assembly composed of two independently acting, approved check valves, including tightly closing resilient seated shutoff valves located at each

end of the assembly and fitted with properly seated test cocks.

flood level rim. The edge of a vessel where a liquid source will start to overflow when capacity is exceeded.

hazard. Any condition or situation that could adversely affect humans, animals, plant life, the environment, or property.

health hazard. Any *hazard* in the judgment of the health department that may cause a danger to the health or well being of an individual.

interchangeable connection. An arrangement or plumbing hardware that allows for the alternate but not simultaneous use of two sources of water or liquids.

non-health hazard. Pollution in a water supply that does not endanger human health but may influence color, odor, or taste of the water.

pollutant. Generally, any substance introduced into the environment that adversely affects the usefulness of a resource. In drinking water, a pollutant is a non-health hazard contaminant that will usually affect the color, odor, or taste of water.

pressure vacuum breaker (PVB). A component of a backflow prevention device or assembly that uses a spring loaded check valve(s).

reduced pressure principle (RPP) or sometimes referred to as reduced pressure zone (RPZ).

A backflow prevention assembly designed to operate on the basis of two independent check valves operating at different pressures separated by a chamber or “zone” that contains a relief valve.

severe health hazard. Contamination in a water supply that could result in severe morbidity or mortality to an individual.

thermal expansion. The expansion in volume of a liquid in a distribution system, container or tank when temperatures are elevated beyond the normal ambient or resting temperature of the liquid.

water supplier or purveyor. The person(s) or organization responsible for supplying potable water to the public.

water borne disease. Any disease or pathogen that is transmitted through a water source.

vacuum breaker. A backflow prevention device that is activated when there is a negative or less than atmospheric pressure operating on the valve.

BIBLIOGRAPHY

American Water Works Association. Recommended Practice for Backflow Prevention and Cross-Connection Control. (1990).

Building Officials and Code Administrators International, Inc. The BOCA National Plumbing Code: Commentary. (1988).

Cross Connection Control Commission of Utah, Division of Drinking Water. The Cross Connection Control Program of Utah. (1996).

Foundation for Cross-Connection Control and Hydraulic Research. Manual of Cross-Connection Control. Ninth Edition. University of Southern California (1993).

Michigan Department of Public Health, Division of Water Supply. Cross Connection Rules Manual. Second Edition. (1982).

State of Ohio Environmental Protection Agency, Division of Public Water Supply. Backflow Prevention and Cross-Connection Control. Third Edition. (1987).

Tillman, Glenn M. “How to Set Up a Basic Cross-Connection Control Program”. On Tap: Drinking Water News for America’s Small Communities. Volume 2, Issue 4. National Drinking Water Clearinghouse. Fall 1993.

U.S. Environmental Protection Agency, Office of Water. Cross-Connection Control Manual. U.S. Government Printing Office, Washington D.C. (1989).

Wisconsin Department of Industry, Labor and Human Relations, Bureau of Building Water Systems. Cross-Connection Control Manual. (1994).